

Bedienungsanleitung Operating Instructions Mode d'emploi

Schüttler / Shaker / Agitateur

**KL 2
WS 10
SM 30 A**

**KS 15 A
TL 10
SM 30 B**

**KS 15 B
TiMix 2
SM 30 C**

TiMix 5

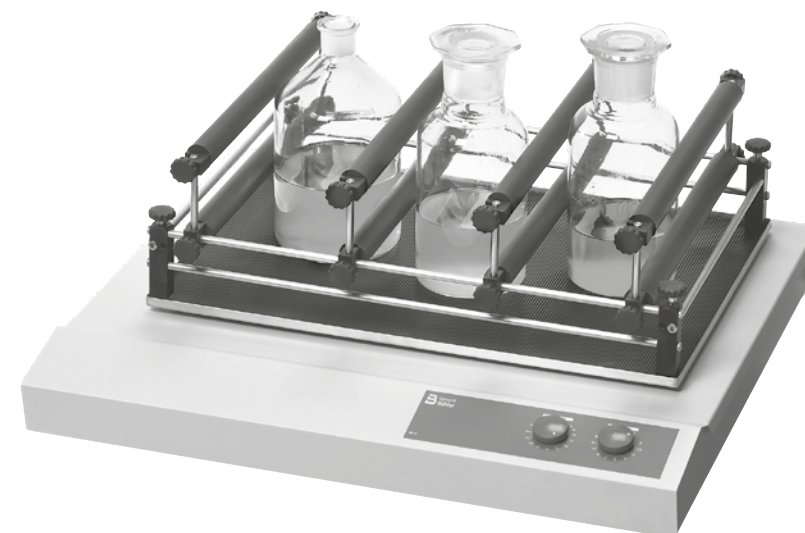

Operating Instructions
Shaker

Thank you for having chosen an original Bühler product.

KL 2
WS 10
SM 30 A

KS 15 A
TL 10
SM 30 B

KS 15 B
TiMix 2
SM 30 C

TiMix 5

Contents		
1. General Notes	6	
1.1 General Notes Concerning Areas of Application and Mode of Operation	7	
1.2 Safety Instructions	8	
2. Transport Instructions	8	
3. Installation and Connection	9	
4. Operation of the Models	10	
4.1 Operating Panel	10	
4.2 The behaviour of the device after voltage outage	10	
4.3 Changing the Motion	10	
4.3.1 Dual Action Shaker KL 2	10	
4.3.2 Universal Shaker SM 30 C	11	
4.4 Change of Angle of Inclination (Three-Dimensional Shaker TL 10)	11	
4.5 Adjustment of the Counterweight (TiMix 5)	12	
4.6 Exchange of Rack Systems of KS 15 / TiMix 2 / TiMix 5	14	
4.6.1 Compact Shaker KS 15	14	
4.6.2 Microplate Shaker TiMix 2	14	
4.6.3 Microplate Shaker TiMix 5	14	
4.7 Fastening of Multi-Storey Rack Systems on Shakers WS 10 / TL 10 / SM 30 / TiMix 5	15	
4.7.1 Tilt Shaker WS 10 / Three-Dimensional Shaker TL 10	15	
4.7.2 Universal Shaker SM 30 A / B / C	15	
4.7.3 Microplate Shaker TiMix 5	15	
5. Maintenance and Servicing Instructions	16	
5.1 Exchange of the Fuse	16	
5.2 Motor Protection	16	
6. Maximum Shaking Speed	17	
6.1 Universal Shaker SM 30	17	
7. CE Declaration of Conformity	18	
8. Warranty	19	
9. Technical Data	20	
10. Basic Equipment	21	
11. Rack Systems and Loading Capacities	22	
11.1 Rack Systems for TiMix 2	22	
11.2 Rack Systems for WS and TL	23	
11.3 Rack Systems for KS	24	
11.3.1 Additional Strips for KL and Combifix KS	25	
11.3.2 Loading Capacity of Rack System Combifix KS	27	
11.3.3 Loading Capacity of Universal Tray KS	27	
11.4 Rack Systems for TiMix 5	28	
11.5 Rack Systems for SM	29	
11.5.1 Loading Capacity of Rack Systems Combifix SM	32	
11.5.2 Loading Capacity of Universal Tray SM	32	

1. General Notes

You have chosen a Bühler high-quality product for supporting you in your work. All Bühler shakers were developed for the use in laboratories in a neutral environment. To ensure a long life and optimal operation of the device we recommend to observe the following points.



Read the operating manual carefully before initial operation.



The user must acquaint himself with the safety instructions and operating conditions in order to avoid damage / injuries to material and personnel.



Liability and all claims under warranty end immediately in case of damages which result from misuse and / or abuse.



The devices were carefully checked for perfect functioning and condition before delivery.



Necessary servicing or repair work may only be done by

- personnel of the manufacturer (Edmund Bühler GmbH)
- their authorized agents
- personnel trained by Bühler



For shipping, the device must be adequately and safely packed. If possible, use the original packing.



If the device is returned to Bühler for repair, it should be cleaned and free from any harmful substances or residues.

These operating instructions are protected by copyright. Modifications reserved.

1.1 General Notes Concerning Areas of Application and Mode of Operation

The devices can be used in all laboratory fields in which it is necessary to mix and shake homogeneously under constant and defined conditions.

Areas of Application (Examples)

- Homogeneous mixing of different liquids as well as of solid and liquid components (e.g. nutrient solutions)
- Shaking of kits for diagnostic tracing reactions
- Solvent extraction of different phases in separating funnels for chemical investigations
- Evenly changing agitation of liquid phase (nutrient solutions) or gaseous phase (cell culture in Petri dishes)
- Coloring and decoloring of gels

Thanks to their different motions and high loading capacities, and especially their variable „Combifix“ rack systems, Bühler shakers offer solutions both for general as well as individual shaking tasks.

For keeping the samples at constant temperatures, the shaker models SM 30, KS 15 and TiMix 5 can be equipped with an additional incubator hood. Temperature range: +5°C above ambient up to +50°C, optionally up to +60°C. A cooling coil for connection of an external flow-through cooler is available as an option (TH 30).

Incubator Hood TH 15 (Order No. 6161 000)

Incubator Hood TH 30 (Order No. 6162 000)

In case of enquiries please contact the Export Sales Department

Tel.: +49 74 71 / 98 64 - 0

Fax: +49 74 71 / 98 64 - 75

e-mail: info@edmund-buehler.de

1.2 Safety Instructions



When shaking aggressive liquids / substances there is a risk of injuries caused by splashing or spilling. Work with adequate protective equipment only. In general, avoid splashing by choosing a suitable shaking speed.



Due to the movements of the device there is danger of clothing or body parts getting caught. During operation pay attention that neither clothing nor jewellery get into contact with moving parts.



The maximum permissible shaking speed depends on the load. See chapter 6 for max. shaking speeds.

2. Transport Instructions

Safe transport of the devices is only ensured if original packaging is used. If they are bumped hard or put down roughly, damages can occur.



Do not lift the devices at the shaking plate (tray)!
Transport the devices by holding them at the housing only!

3. Installation and Connection

Place the shaker on a level, smooth and firm surface so that it stands firmly also at high shaking frequencies. For connection requirements and operating voltage see technical data as well as the rating plate at the back of the device.



The system may only be connected to a mains with protection earth!



When installing the devices make sure that they are protected against splash water.



The safety distance between the device and other instruments or a wall must be chosen in such a way that the shaking plate is freely movable and that the operating personnel cannot be injured when the shaker is switched on or during operation.
If other tasks are performed by personnel in immediate vicinity of the shaker, the shaker must be switched off for reasons of safety.

4. Operation of the Models

4.1 Operating Panel

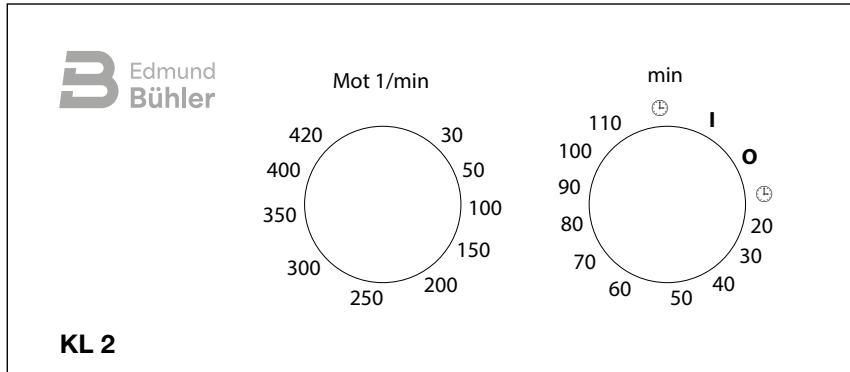

The operating panel for the listed shakers has two control knobs. With the left one the required speed can be adjusted (speed range see Technical Data!).

The right control knob (timer function) has the positions „0“ (off) and „I“ (on/continuous operation) as well as a timer function which can be chosen between 10 - 120 min.

4.2 The behaviour of the device after voltage outage

With the „I“ setting (On / continuous operation), the shaker restarts after a voltage outage.

With a time preset, the timer continues to run during a voltage outage, the shaker then restarts automatically and the set runtime continues to run down.

4.3 Changing the Motion

4.3.1 Dual Action Shaker KL 2

The motion can be changed by means of the coupling lever at the right side. The coupling lever must audibly snap into its final position.

- Pull out coupling lever -> orbital motion
- Push in coupling lever -> to-and-fro motion



Change the motion only when the device is running with minimum speed!
Changing the shaking motion at high speed can cause damages to the device.

4.3.2 Universal Shaker SM 30 C

The motion can be changed by actuating the lever at the front of the shaking plate:

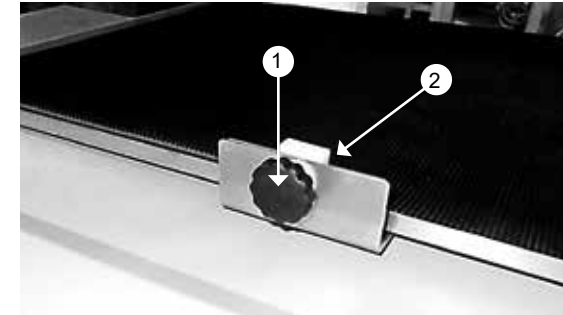

- Loosen the star-shaped knob (1) at the front of the shaking plate and move lever (2) to the desired position.

Position	Motion
Lever at the right position	To-and-fro motion
Lever at the left position	Orbital motion

- After having chosen the motion, tighten the star-shaped knob again.



Change the motion only while the device is running at minimum speed!
Changing the motion at high speed can damage the device.

4.4 Change of Angle of Inclination (Three-Dimensional Shaker TL 10)

In order to adjust the angle of inclination remove the rubber mat. Verify on which side the shaker is inclined by pressing all 4 sides. The angle of inclination can be adjusted steplessly. Insert the pin (accessory) into the drilling of the shaking plate as far as possible. Use the allen key (accessory) to turn the screw anti-clockwise to the stop. Loosen the screw and adjust the angle of inclination. Then turn the screw clockwise to the stop, fix the screw and remove the pin from the drilling.

4.5 Adjustment of the Counterweight (TiMix 5)

The shaker model TiMix 5 has an adjustable counterweight with which load changes of up to 5 kg can be compensated.



Before changing the counterweight, disconnect the device from the mains!

The finder sleeve (2) for an adjustment of the counterweight (7) is at the left side of the shaker (see drawing no. 0240 089).

- For changing the counterweight (7) the adjustment spindle (3) must be positioned exactly in the direction of the finder sleeve (2) (see. fig. 1). Switch the shaker off, turn the shaking plate (9) by hand into the furthest position at the right, then the adjustment spindle (3) and the counterweight (7) are at the left side in the direction of the finder sleeve (2). Control the position of the adjustment spindle (remove the cover (1), and look through the finder sleeve).
- Insert the tubular socket wrench (8) through the finder sleeve (2) and onto the positioning nut (4) by turning the socket wrench (8) slightly to the right or to the left so that it hooks on. Now separate the counterweight (7) from the positioning nut (4) by pressing the socket wrench (8) to the limit overcoming a slight spring pressure (see fig. 2). The travel of the spring is approx. 3 mm.
- The counterweight can now be adjusted according to the load by turning the socket wrench (8) to the left or to the right. For heavy loads (max. 5 kg) turn the socket wrench to the left. For light loads, turn it to the right.
- Before removing the socket wrench (8) make sure that the positioning pin (5) is fixed in one of the positioning drillings (6) of the positioning nut (4) by pulling the socket wrench back by approx. 3 mm (see fig. 3). In this position, the socket wrench should no longer be turnable.

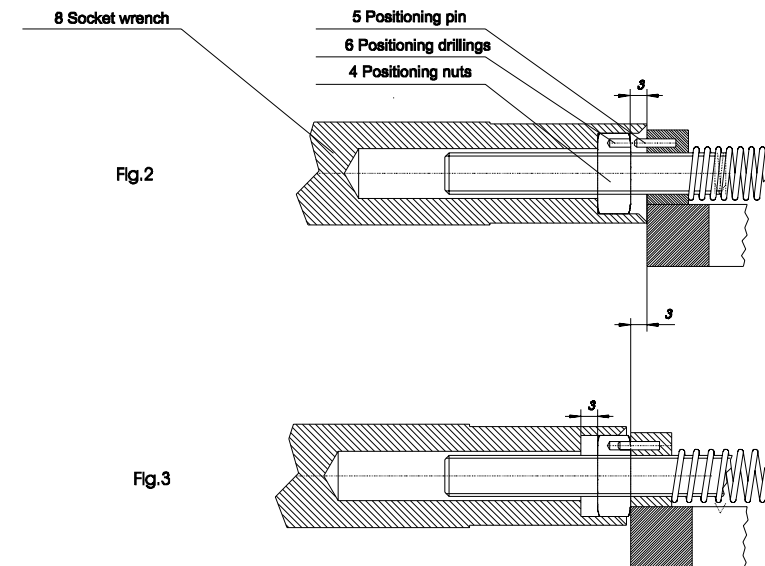
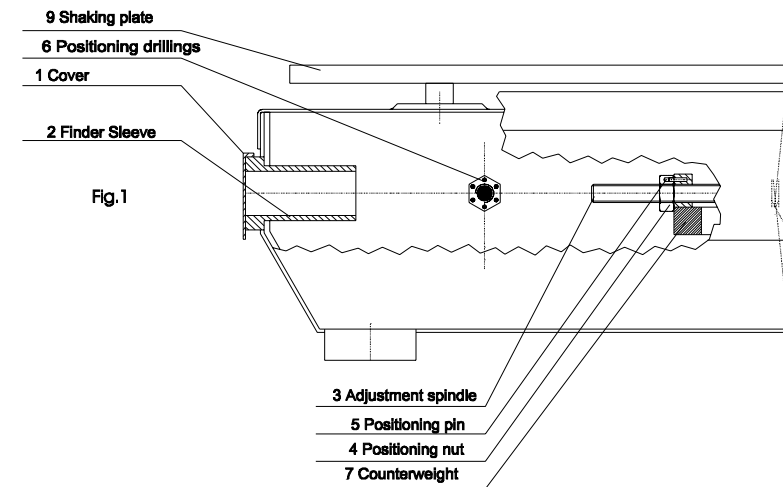

4.6 Exchange of Rack Systems of KS 15 / TiMix 2 / TiMix 5

4.6.1 Compact Shaker KS 15

The KS 15 shakers can be delivered with 2 alternative rack systems:
Rack system Combifix KS (No. 0052 071) with 3 clamping strips h or universal tray KS (No. 0051 471) for spring clamps (see Accessories / Rack Systems).

If you wish to change the rack system, proceed as follows:

For mounting the universal tray, the Combifix KS must be removed.
Remove the rubber mat and loosen the flat headed screws of the rack system.
Remove rack system. Fasten the universal tray KS with the flat headed screws and the distances which are delivered with the universal tray.

To mount the Combifix KS, proceed in reverse order.

4.6.2 Microplate Shaker TiMix 2

As an alternative to the integrated standard rack for 4 microplates the shaking plate of the KM 2 shaker (No. 0052 072) can also be mounted.

Loosen the 3 flat headed screws (M6x16) and remove the rack system. Fasten the shaking plate to the respective drillings with the same screws and put the rubber mat on the shaking plate.

4.6.3 Microplate Shaker TiMix 5

The TiMix 5 shakers can be combined with different rack systems for microplates or with the Combifix KS (No. 0052 071) or the universal tray KS (No. 0051 471) (see Accessories / Rack Systems).
These rack systems can be exchanged without problems.
Loosen the flat headed screws of the rack system or tray and fasten the required rack system instead.

4.7 Fastening of Multi-Storey Rack Systems on Shakers WS 10 / TL 10 / SM 30 / TiMix 5

4.7.1 Tilt Shaker WS 10 / Three-Dimensional Shaker TL 10

The multi-storey rack system WS/TL (No. 0051 247) is fastened with screws to the corresponding drillings at the back of the basic tray. Place the short black rails on the inside of the basic tray. Then fasten the knurled screws to the tray and the holes in the black rails, then tighten the screws. The additional trays can be inserted in any of the guides of the rack system.

4.7.2 Universal Shaker SM 30 A / B / C

Mount the 2-storey top frame as described in the respective separate manual included in the delivery of the 2-storey top frame.

4.7.3 Microplate Shaker TiMix 5

The additional tray is delivered with mounted distance bolts. First remove the standard rack system from shaker (4 flat head screws M6). Then mount the additional tray with these screws onto the shaker. Then mount the standard rack system with the delivered screws on the distance bolts of the additional tray.

5. Maintenance and Servicing Instructions

The devices are maintenance-free; excessive soiling should be avoided.

In case of failure, please contact the Technical Service Department of the Edmund Bühler GmbH.

Edmund Bühler GmbH
 Technical Service Dept.
 Schindäckerstraße 8
 D-72411 Bodelshausen
 Telefon: 07471 / 9864-0
 Telefax: 07471 / 9864-75
 e-mail: info@edmund-buehler.de

Ed-

5.1 Exchange of the Fuse

The device is protected against overload by means of a fine fuse (see Technical Data).

The fuse holder is located at the back of the device below the mains plug.
 The fuse can be exchanged after removal of the fuse insert.
 The fuse insert contains 1 spare fuse.



Before removal of the fuse insert disconnect the mains plug!

5.2 Motor Protection

The capacitor drive is equipped with a thermal overload protection. In case of overload, caused e.g. by blocking or if the ambient temperature is too high, the drive is automatically switched off by the thermal protection which is directly inserted in the motor winding. When the winding has cooled down, the drive switches itself on again. The device must be switched off!

In case of defects, switch the device off and send it to the Technical Service Department of the Edmund Bühler GmbH, together with a detailed description of the defect (address: see above).

6. Maximum Shaking Speed



The below specified shaking speeds against load are approximate values. Depending on the specific properties of the substances to be shaken these values can differ marginally.



= Range not permitted.

Attention: Danger of serious damage!

6.1 Universal Shaker SM 30

Maximum load [kg] against shaking speed [rpm]
 with rack system **Combifix SM** or universal tray **SM (1-storey operation)**

Type	Stroke (mm)	15 -180 rpm	200 rpm	220 rpm	240 rpm	260 rpm	280 rpm	300 rpm
SM A	26 mm*	30 kg	30 kg	30 kg	15 kg	10 kg	5 kg	5 kg
SM B	30 mm*	30 kg	30 kg	30 kg	20 kg	15 kg	10 kg	8 kg
SM B	46 mm	30 kg	20 kg	10 kg	10 kg	5 kg		
SM B	50 mm	20 kg	15 kg	10 kg	5 kg			
SM C ○	26 mm*	30 kg	20 kg	15 kg	10 kg	5 kg		
SM C ↔	26 mm*	30 kg	25 kg	20 kg	15 kg	10 kg	5 kg	5 kg

with **2-storey top frame SM**

SM A	26 mm*	25 kg	20 kg	15 kg	8 kg	2 kg		
SM B	30 mm*	30 kg	30 kg	25 kg	20 kg	10 kg	8 kg	5 kg
SM B	46 mm	20 kg	10 kg	5 kg	2 kg			
SM B	50 mm	15 kg	5 kg					
SM C ○	26 mm*	20 kg	20 kg	10 kg	5 kg			
SM C ↔	26 mm*	20 kg	20 kg	15 kg	10 kg	8 kg	5 kg	

* Standard configuration

We recommend to fasten the shaker on the floor or on the table with 4 PVC rings (part no. 0002754) when working with maximum permissible loads.

7. CE Declaration of Conformity

We,

Edmund Bühler GmbH
Schindäckerstraße 8
D-72411 Bodelshausen

Manufacturers of this product, declare under our sole responsibility that this product corresponds to the EC directives 2006/42/EG (machinery directive) and 2014/30/EU / 2014/35/EU (EMC directive).

The following harmonised standards apply:

EN 55 014; EN 61 000; EN 61 010; EN 60 204; EN ISO12100

For the shaker models SM 30 the following standards apply:

EN 61 000-3-2 : 2023
EN 61 000-3-3 : 2023
EN 55 011 : 2022

Responsible for the documentation:
Dipl.-Ing. (FH) Michael Schlecht



Edmund Bühler GmbH
CEO

8. Warranty

The Edmund Bühler GmbH warrants that this device has the properties guaranteed by contract and that it does not have any defects which rescind its value or its use for customary and usual applications or applications foreseen by the contract. (See General Terms and Conditions of the Edmund Bühler GmbH).

The warranty period ends 24 months after delivery (date of invoice).

The warranty does not include wear parts. Excluded from warranty are malfunctions caused by misuse or improper use, installation, or maintenance.

Warranty ends immediately if the device is subjected to technical modifications which are not authorized in advance by Edmund Bühler GmbH.

9. Technical Data

Shaker Model	KL 2	KS 15	SM 30	WS 10	TL 10	TMix 2 / TMix 5
Order No.	6115 000	6171 000 (A) 6173 000 (B)	6101 000 (A) 6103 000 (B) 6105 000 (C)	6114 000	6117 000	6110 000 (TMix 2) 6166 000 (TMix 5)
Speed range	30-420 rpm	30-420 rpm	15 - 300 rpm	1 - 23 rpm	1 - 23 rpm	100 - 1400 rpm
Angle of tilt / inclination	-	-	-	5° fix	0 - 9° adjustable	-
Shaking amplitude (Stroke)	8 mm	17 mm	Model A/C: 26 mm Model B: 30 mm (Option: 46 / 50 mm)	-	-	3 mm
Loading capacity	max. 2 kg	max. 15 kg	max. 30 kg	max. 10 kg	max. 10 kg	max. 2 kg (TMix 2) max. 5 kg (TMix 5)
Shaking plate (WxD) mm	300 x 300	400 x 300	560 x 400	340 x 340	340 x 340	200 x 295 (TMix 2) 400 x 300 (TMix 5)
Timer <small>∞ = continuous operation</small>	0 -120 min / ∞	0 -120 min / ∞	0 -120 min / ∞	0 -120 min / ∞	0 -120 min / ∞	0 -120 min / ∞
Electrical supply	230 V, 50/60 Hz	230 V, 50/60 Hz	230 V, 50/60 Hz	24 V DC, 50/60 Hz	230 V, 50/60 Hz	230 V, 50/60 Hz
Fuse	125 W / 0,63 AT	125 W / 0,63 AT	140 W / 1 AM	-	125 W / 0,63 AT	125 W/1 AM (TMix 2) 140 W/1 AM (TMix 5)
Dimensions (WxDxH) mm	355 x 455 x 195	510 x 490 x 150	680 x 610 x 160	355 x 450 x 205	355 x 450 x 205	220 x 410 x 110 (TMix 2) 510 x 490 x 150 (TMix 5)
Weight	13,5 kg	18 kg	33 kg	18,5 kg	18,5 kg	8,5 kg (TMix 2) 19 kg (TMix 5)
Type of protection	IP 21	IP 21	IP 21	IP 21	IP 21	IP 21
Heat emission (appr.)	approx. 4 W	approx. 5 W	approx. 7 W	approx. 3 W	approx. 6 W	approx. 6 - 9 W
Ambient temperature	5°C to 50°C	5°C to 50°C	5°C to 50°C	5°C to 50°C	5°C to 50°C	5°C to 50°C
Max. rel. humidity	85 %	85 %	85 %	85 %	85 %	85 %

10. Basic Equipment

Dual-Action Shaker KL 2	Basic device incl. rack system with 3 clamping strips h and rubber mat
Compact Shaker KS 15	Basic device without shaking plate, without rack system
Universal Shaker SM 30	Basic device with shaking plate and rubber mat
Tilt Shaker WS 10	Basic device incl. basic tray and rubber mat
Three-Dimensional Shaker TL 10	Basic device incl. basic tray and rubber mat 1 wrench for changing the angle of inclination
Microplate Shaker TiMix 2	Basic device incl. basic platform with holders for 4 standard microplates (96 samples)
Microplate Shaker TiMix 5	Basic device without shaking plate, without rack system Socket wrench to adjust the counter-weight

11. Rack Systems and Loading Capacities

11.1 Rack Systems for TiMix 2

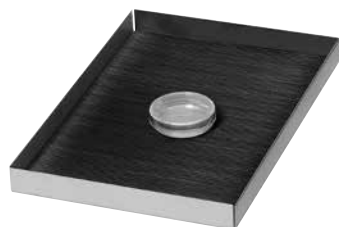

Shaking platform KM

Shaking platform KM
For shaker TiMix 2 (instead of
standard platform). Flat shaking
platform with rim (20 mm) and
rubber mat.

Shaking platform 200 x 295 mm

Order No. 0052 072



Clamping strips KM for shaking platform KM

Order No. 0052 115

11.2 Rack Systems for WS and TL



Multi-storey rack system

With 2 trays (340 x 340 mm) and
rubber mats for shakers WS 10 and
TL 10

Order No. 0051 247

Tray WS/TL (340 x 340 mm)

Additional tray for multi-storey rack
WS/TL incl. rubber mat.

Order No. 0051 502

Tray WS/TL (340 x 500 mm)

Additional tray for multi-storey rack
WS/TL incl. rubber mat.

Order No. 0051 413

11.3 Rack Systems for KS



Rack system Combifix KS

Consisting of basic rack with rubber mat and 3 clamping strips h for KS

Order No. 0052 071

11.3.1 Additional Strips for KL and Combifix KS

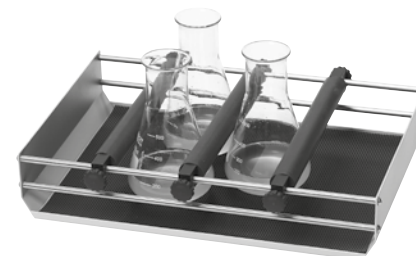

All flat-bottom vessels (Erlenmeyer flasks, beakers, test tube racks, sieves, etc.) can easily be fixed on the shaker with the clamping strips h. In addition to the clamping strips h supplied with the Combifix KS.

Clamping strip h for KS

Order No. 0050 118



Universal tray KS

For secure fastening of Erlenmeyer flasks, round bottom flasks, or beakers in single stainless steel spring clamps. The drillings (28.3 mm apart) ensure flexible loading and a high loading capacity.

The coated tray is proof against aggressive liquids.

Universal tray KS, without spring clamps

Order No. 0051 471

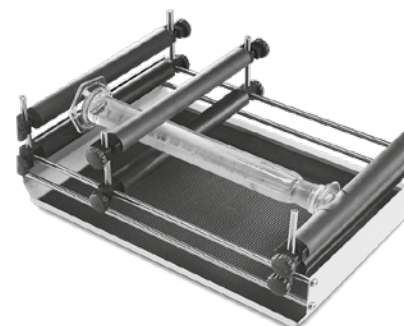

The clamping strips v are used in combination with the clamping strips h in order to fasten horizontal vessels, e.g. measuring cylinders, between the strips, or as added support for high vessels (flasks, beakers, cylinders). The maximum distance between the strips is 60 mm. In addition to the clamping strips h.

Clamping strip v for KS

Order No. 0050 477



The cramp strips and spring strips are necessary for fastening separating funnels. The necks of the separating funnels are fastened in the grey plastic clamps, the spring strip secures the stoppers. The stems of the separating funnels are placed on a clamping strip h. For a modification of the standard rack system or in addition to the clamping strips h.

Cramp strip for KS

Order No. 0050 206

Spring strip for KS

Order No. 0050 207

11.3.2 Loading Capacity of Rack System Combifix KS

	Size	Qty (pcs)
Erlenmeyer flasks	50 ml	25 ¹⁾
	100 ml	20 ¹⁾
	250 ml	12 ²⁾
	500 ml	6 ³⁾
	1000 ml	4
	2000 ml	2
	3000 ml	1
	5000 ml	1
Separating funnels	100 ml	4 ⁴⁾
	250 ml	1 ⁴⁾
	500 ml	1 ⁴⁾
	1000 ml	1 ⁴⁾
	2000 ml	1 ⁴⁾
	Test tube racks	

¹⁾ with 3 clamping strips h (0050 118) additional ²⁾ with 2 clamping strips h (0050 118) additional

³⁾ with 1 clamping strip h (0050 118) additional ⁴⁾ with 1 clamp strip (0050 206) and 1 spring strip (0050 207) additional

11.3.3 Loading Capacity of Universal Tray KS

	Size	Qty (pcs)
Spring clamps	10 ml	70
	25 ml	35
	50 ml	35
	100 ml	20
	250 ml	15
	500 ml	12
	1000 ml	5
	2000 ml	2
	3000 ml	2
5000 ml	1	
Test tube racks (with hinged foot)		3



Spring clamps (stainless steel)

for universal trays.

The sizes are related to Erlenmeyer flasks, but are also suitable for round bottom flasks, beakers, etc.

Size	10 ml	Order No. 0009 642
Size	25 ml	Order No. 0009 643
Size	50 ml	Order No. 0009 644
Size	100 ml	Order No. 0009 645
Size	250 ml	Order No. 0009 646
Size	500 ml	Order No. 0009 647
Size	1000 ml	Order No. 0009 648
Size	2000 ml	Order No. 0009 649
Size	3000 ml	Order No. 0009 653
Size	5000 ml	Order No. 0009 652

Test tube racks, stainless steel

The test tube racks can be fastened either on the standard rack system between the clamping strips h, or they can be screwed on the universal tray by means of a hinged foot. With this foot it is possible to vary the angle of inclination of the test tubes. With:

44 holes à 14 mm Ø
Order No. 0052 056

44 holes à 16 mm Ø
Order No. 0052 057

44 holes à 18 mm Ø
Order No. 0052 058

14 holes à 30 mm Ø
Order No. 0052 201

Hinged foot for test tube racks,
stainless steel
Order No. 0052 059

11.4 Rack Systems for TiMix 5



Standard rack system

For 8 standard microplates, micro-well or deepwell plates, or other plates of the same size.

Order No. 0052 101



Additional tray

As a second storey on the standard rack system TiMix 5. Distance between the 2 trays max. 55 mm.

Order No. 0052 102

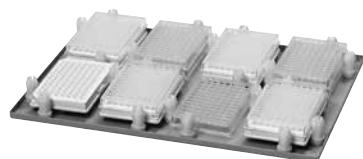

Rack system with clamping pins

For 8 standard microplates (128 x 85 mm)

Order No. 0052 096



Rack system with high clamping pins

For max. 24 standard microplates, placed directly on top of each other

Order No. 0052 104

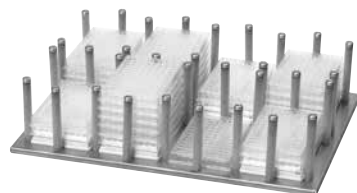

Rack system with metal clamping pins

For max. 48 standard microplates, placed directly on top of each other

Order No. 0052 104

Rack systems Comibfix KS and Universal tray KS

Picture, description and order no. see chapter 11.3

11.5 Rack Systems for SM



Combifix SM, Assembly A

consisting of basic rack and 5 clamping strips h.

Variable rack system for fastening different vessels with flat bottom (Erlenmeyer flasks, beakers, test tube racks, sieves etc.).

Order No. 0050 154

For further extension or for modifying Combifix B or C systems, the clamping strips h are available as separate items:

Clamping strip h for SM

Order No. 0050 400



Combifix SM, Assembly B

consisting of basic rack and 4 clamping strips h + 4 clamping strips v.

Rack system for secure fastening of horizontal vessels, e.g. measuring cylinders, between the clamping strips, or as added support for high vessels (flasks, beakers, cylinders). The maximum distance between the strips is 60 mm.

Order No. 0050 155

For further extension or for modifying Combifix A or C systems, the clamping strips v are available as separate items:

Clamping strip v for SM

Order No. 0050 399

Combifix SM, Assembly C

consisting of basic rack and 2 clamping strips h, 2 clamp strips and 1 spring strip.

Special rack system for separating funnels. The necks of the separating funnels are fastened in the grey plastic clamps, the spring strip secures the stoppers. The stems of the separating funnels are placed on a clamping strip h.

Order No. 0050 156

For further extension or for modifying Combifix A or B systems, the strips are also available as separate items:

Cramp strip for SM

Order No. 0050 401

Spring strip for SM

Order No. 0050 402

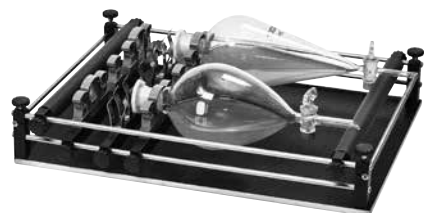

2-storey top frame SM

Top frame with two trays for spring clamps - or for Combifix SM systems.

For easy handling, sliding plates with Combifix SM or universal trays SM can be mounted. These allow loading of the racks away from the shaker.

2-storey top frame SM (without spring clamps or rack systems Combifix SM)

Order No. 0052 065

2-storey top frame SM/TH

Smaller top frame which can be used inside the incubator hood TH 30.

For small or flat sample vessels with a max. height of approx. 14 cm.

The top frame SM/TH can only be used in combination with universal trays SM or sliding plates SM.

2-storey top frame SM/TH (without spring clamps or rack systems Combifix SM)

Order No. 0052 117

Sliding plates SM

Combifix SM systems for multi-storey frames mounted on plates.

Description of the Combifix systems: see page 29/30

Sliding Plate with Combifix SM, Assembly A

Order No. 0051 484

Assembly B

Order No. 0051 485

Assembly C

Order No. 0051 486

Spring clamps / Test tube racks

See chapter 11.3.1

Universal tray SM

Coated aluminium tray. The drillings of the universal tray (28.3 mm apart) allow flexible loading with spring clamps or test tube racks.

The tray is proof against aggressive liquids.

Universal tray SM, without spring clamps.

Order No. 0051 472



11.5.1 Loading Capacity of Rack Systems Combifix SM

	Size	Qty (pcs)
Erlenmeyer flasks	50 ml	49 ¹⁾
	100 ml	42 ¹⁾
	250 ml	20 ²⁾
	500 ml	12
	1000 ml	6
	2000 ml	6
	3000 ml	4
	5000 ml	2
Separating funnels	100 ml	10
	250 ml	6
	500 ml	4
	1000 ml	4
	2000 ml	1 - 2 ³⁾
Test tube racks		4

¹⁾with 3 clamping strips h (0050 400) additional ²⁾with 1 clamping strip h (0050 400) additional

³⁾ Number of pieces depends on shape and dimensions of the separating funnels

11.5.2 Loading Capacity of Universal Tray SM

	Size	Qty (pcs)
Spring clamps	10 ml	118
	25 ml	64
	50 ml	63
	100 ml	31
	250 ml	24
	500 ml	14
	1000 ml	11
	2000 ml	6
	3000 ml	4
	5000 ml	2
Test tube racks (with hinged foot)		5



B Edmund Bühler

Edmund Bühler GmbH
Schindäckerstraße 8
72411 Bodelshausen / Germany
Tel.: +49 7471 9864-0
info@edmund-buehler.de

Version 11/2024
Technische Änderungen und Irrtum vorbehalten.
Subject to technical alterations and mistakes.

www.edmund-buehler.de 